

SIDE VIEW

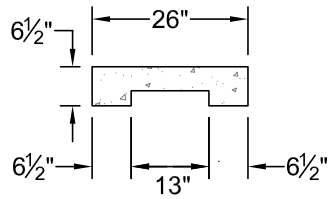

END VIEW

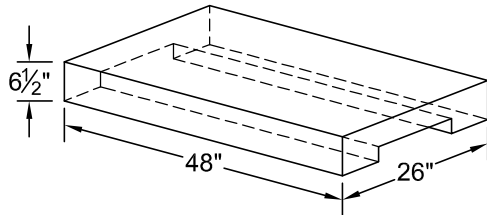
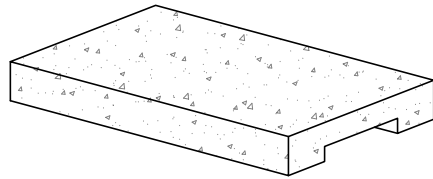

CAPSTONE

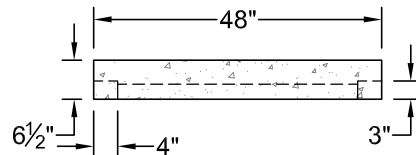

SIDE VIEW

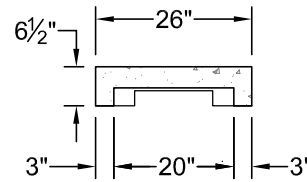

END VIEW

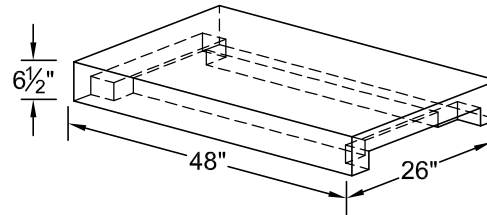
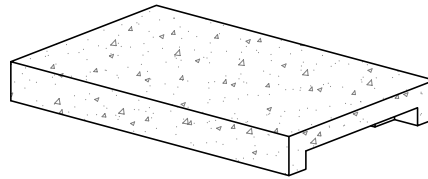

FITTING CAPSTONE

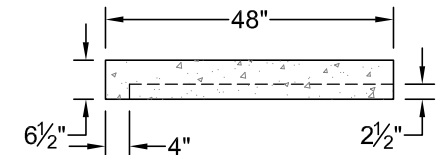

SIDE VIEW

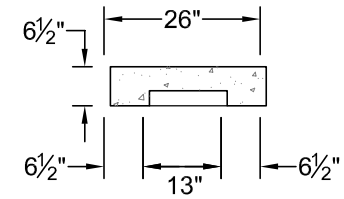

END VIEW

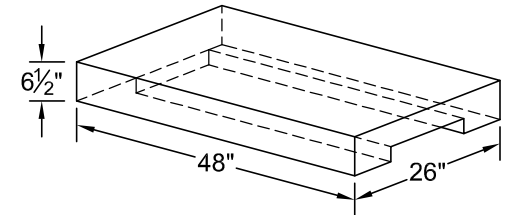
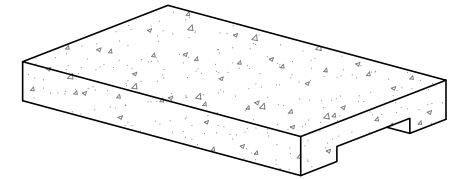

END CAPSTONE

NOTE: CAPSTONES WEIGH APPROXIMATELY 600 POUNDS AND SHOULD BE INSTALLED USING A SCISSORS CLAMP WITH PROTECTIVE RUBBER GRIPS ON THE INSIDE OF EACH CLAMP. ADDITIONALLY, CAPSTONES WILL NEED TO BE CUT WHEN INSTALLED ON CURVED WALLS OR WHEN A HALF CAPSTONE IS REQUIRED. IT IS RECOMMENDED THAT FITTING CAPSTONES BE UTILIZED WHEN CURVED WALLS ARE BEING CONSTRUCTED TO REDUCE THE CAPSTONE CUTTING TIME. ALL CAPSTONES SHOULD BE ADHERED TO THE BLOCK BELOW USING CONCRETE ADHESIVE (PL PREMIUM).

© Copyright 2016 ReCon Wall Systems, Inc. All Rights Reserved

Disclaimer: This drawing has been prepared by ReCon Wall Systems, Inc. and to the best of its knowledge, accurately represents the product use in the application that it is illustrated. This drawing is intended for conceptual purposes only. Anyone making use of this drawing does so at their own risk and assumes all liability for such use. Final design for construction purposes must be completed by a Registered Professional Engineer who is familiar with the product and who has taken into account specific site conditions.



DRAWING #701

CAPSTONE UNIT DETAILS

RECON WALL SYSTEMS, INC.
7600 W. 27th STREET, #229
ST. LOUIS PARK, MN 55426
952-922-0027
www.reconwalls.com

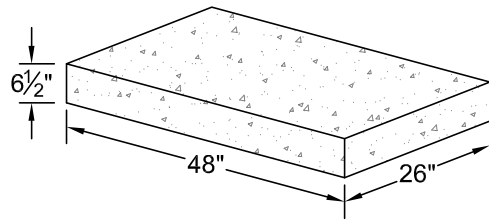

STEP UNIT

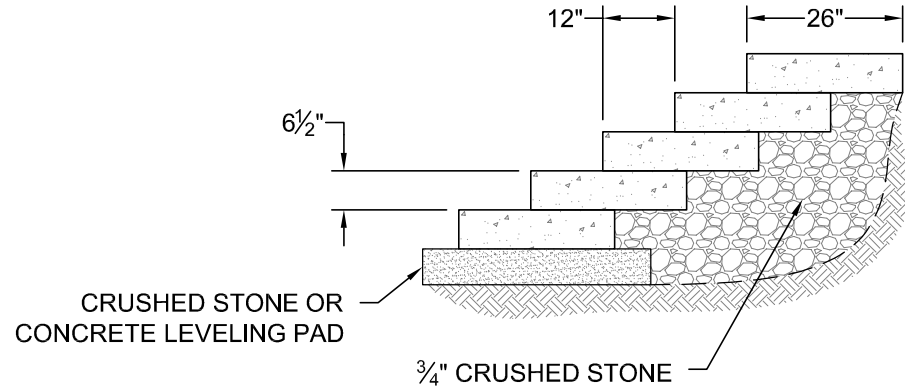

SECTION DETAIL

NOTES:

1. EACH STEP SHOULD BE ADHERED TO THE STEP BELOW USING CONCRETE ADHESIVE (PL PREMIUM IS RECOMMENDED).
2. EACH STEP WEIGHS APPROXIMATELY 650 POUNDS. THE STEPS SHOULD BE INSTALLED USING A SCISSORS CLAMP WITH PROTECTIVE RUBBER GRIPS ON EACH SIDE OF THE CLAMP.
3. CARE SHOULD BE TAKEN IN PRE-PLANNING THE RISE OVER RUN OF THE STEP UNITS. THE DEPTH OF THE STAIR TREAD CAN BE MODIFIED BY CHANGING THE OVERLAP OF THE STEP UNITS. CHECK LOCAL CODE FOR MINIMUM TREAD DEPTH REQUIREMENTS.
4. THE INDIVIDUAL STEPS ARE PRODUCED WITH A HEIGHT OF 6 1/2" HEIGHT, HOWEVER, WHEN THE STEP UNITS ARE STACKED ON TOP OF EACH OTHER THE ACTUAL ELEVATION CHANGE FROM STEP TO STEP MAY EXCEED 6 1/2". THIS MAY BE CAUSED BY SEVERAL FACTORS INCLUDING:
 - SLIGHT, YET ACCEPTABLE, TOLERANCE VARIATION ATTRIBUTABLE TO THE PRODUCTION PROCESS ($\pm 3/16"$)
 - INTENTIONAL UNEVENNESS IN THE TEXTURE ON THE TOP OF THE STEP UNIT
 - THE THICKNESS OF THE GLUE USED BETWEEN EACH STEP UNIT
 IF THE ELEVATION AT THE TOP OF A STEP (OR A LANDING AREA WITHIN THE STEPS) IS CRITICAL, IT IS RECOMMENDED THAT THE DESIGN ASSUME A 7" RISE. SHIMS MAY BE ADDED DURING THE INSTALLATION IF STEPS ARE STACKING AT LESS THAN A 7" HEIGHT.
5. IF THE STEPS BEING CONSTRUCTED PROTRUDE BEYOND THE FACE OF THE ADJACENT RETAINING WALL, IT IS RECOMMENDED THAT TWO STEP UNITS BE PLACED AT EACH COURSE (ONE IN FRONT AND ONE BEHIND). THIS WILL PROTECT THE STEP UNITS FROM EROSION AND SCOUR ALONG THE SIDES WHERE THEY PROTRUDE BEYOND THE RETAINING WALL FACE AND PROVIDE PROPER BEARING OF EACH STEP UNIT COURSE.

© Copyright 2016 ReCon Wall Systems, Inc. All Rights Reserved

Disclaimer: This drawing has been prepared by ReCon Wall Systems, Inc. and to the best of its knowledge, accurately represents the product use in the application that it is illustrated. This drawing is intended for conceptual purposes only. Anyone making use of this drawing does so at their own risk and assumes all liability for such use. Final design for construction purposes must be completed by a Registered Professional Engineer who is familiar with the product and who has taken into account specific site conditions.



DRAWING #702

**STEP UNIT
DETAILS**

RECON WALL SYSTEMS, INC.
7600 W. 27th STREET, #229
ST. LOUIS PARK, MN 55426
952-922-0027
www.reconwalls.com

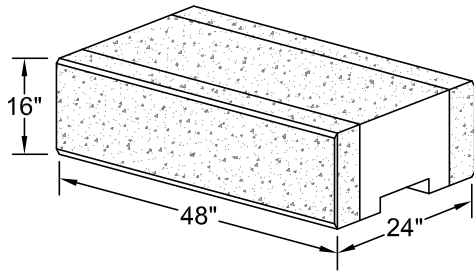

**FULL-HIGH CAP
MIDDLE BLOCK**

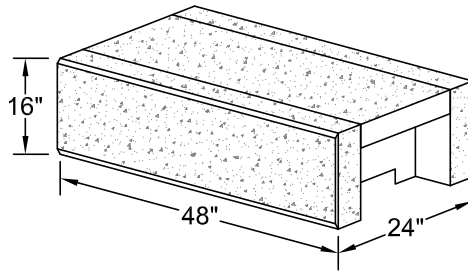

**FULL-HIGH CAP
FITTING BLOCK**

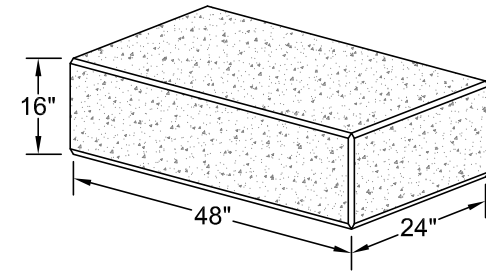

**FULL-HIGH CAP
END BLOCK**

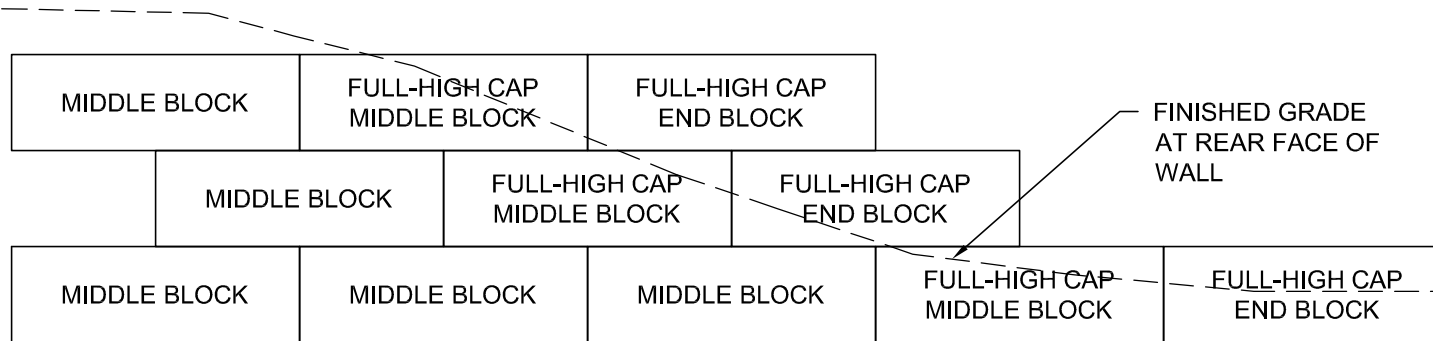

**PARTIAL WALL PROFILE
TYPICAL APPLICATION**

NOTES:

1. WHEN A RETAINING WALL IS CONSTRUCTED THAT IS SUPPORTING A ROAD OR SIDEWALK AND THE GRADE OF THE ROAD OR SIDEWALK IS NOT LEVEL, IT MAY BE HELPFUL TO USE FULL-HIGH CAP BLOCKS AT THE ENDS OF EACH COURSE OF THE WALL. THIS WILL PROVIDE TEXTURE ON THE BACK SIDE OF THE WALL (SIDE FACING ROAD OR SIDEWALK) UNTIL GRADE IS SUFFICIENT TO COVER THE UN-TEXTURED BACK OF A TYPICAL WALL BLOCK.
2. IF THE WALL IS CURVED, THE FULL HIGH CAP WILL NEED TO BE MITER CUT IN THE FIELD TO CLOSE THE GAP BETWEEN THE BLOCKS. IN THIS SITUATION IT IS RECOMMENDED THAT FULL HIGH CAP FITTING BLOCKS BE USED TO SAVE TIME AND EXPENSE ON BLOCK CUTTING.

© Copyright 2016 ReCon Wall Systems, Inc. All Rights Reserved

Disclaimer: This drawing has been prepared by ReCon Wall Systems, Inc. and to the best of its knowledge, accurately represents the product use in the application that it is illustrated. This drawing is intended for conceptual purposes only. Anyone making use of this drawing does so at their own risk and assumes all liability for such use. Final design for construction purposes must be completed by a Registered Professional Engineer who is familiar with the product and who has taken into account specific site conditions.



DRAWING #703

**FULL-HIGH CAP BLOCK
DETAILS**

RECON WALL SYSTEMS, INC.
7600 W. 27th STREET, #229
ST. LOUIS PARK, MN 55426
952-922-0027
www.reconwalls.com